

FUJITEC

<http://www.fujitec.com.cn>



FUJITEC

GS AUTOWALK 8100

TYPE GS8100-S

TYPE GS8100-F

TYPE GS8100-P



AUTOWALK (Horizontal / Inclined type)

Fujitec's user-friendly GS8100 autowalk serves passengers with its exceptional smoothness and quietness. Inclined type is also available.

User-friendly

Superb riding comfort

Exceptional smoothness & quietness

High Quality

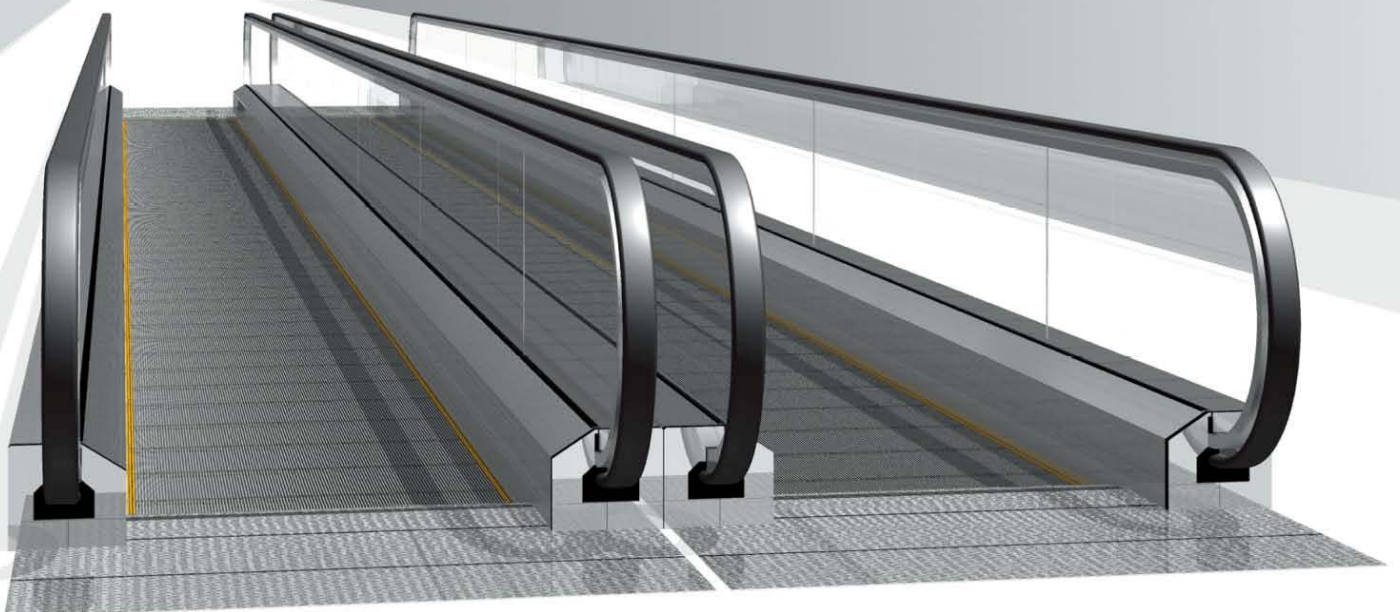

Variety of Types

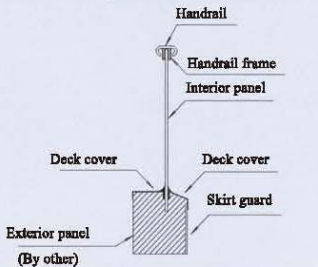
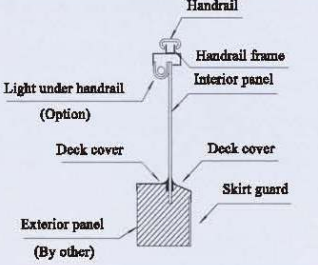
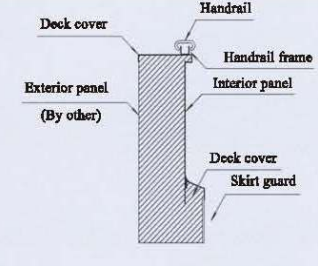
<p>Type-S</p>	<p>[Slim type] Interior panels are made of clear tempered glass which provides a sophisticated appearance.</p> <p>Indoor use.</p>	
<p>Type-F</p>	<p>[Frame type] (Lighting is option) Interior panels are made of clear tempered glass. Optional lighting under the handrails creates an elegant look.</p> <p>Indoor & Outdoor use.</p>	
<p>Type-P</p>	<p>[Panel type] Interior panels are made of hairline-finished stainless steel and are ideally suited for public transit systems.</p> <p>Indoor & Outdoor use.</p>	

Inclined type
Angle of inclination is 12° For Model S800 and S1000

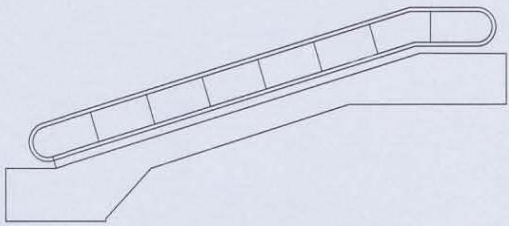

Horizontal type
Angle of inclination is 0° For Model S1000 and S1400

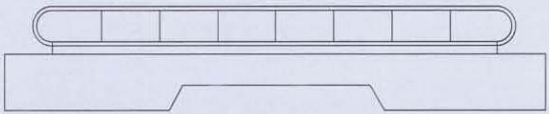

Specifications

●: Standard Spec. ■: Optional Spec.

Balustrade		
Handrail	Synthetic Rubber (black)	■
	Polyurethane (black)	●
	Polyurethane (7 colors)	■
Handrail Frame	Hairline-finished Stainless Steel	●
Deck Cover		
Interior Panel	Type-F,S: Colorless, Clear Tempered Glass	●
	Type-P: Hairline-finished Stainless Steel	●
Skirt Guard	Hairline-finished Stainless Steel	●
	Teflon-coated Steel (black&gray)	■
Pallet		
Tread	Aluminum Alloy Die-cast (gray) S800, S1000	●
	Stainless Steel S1400	●
	Aluminum Alloy Die-cast (gray) S1400	■
Demarcation Line	Painted (yellow) [For Model S800 and S1000] Synthetic Resin (yellow) [For Model S1400]	●
Floor Plate		
Comb	Aluminum Alloy Die-cast	●
Landing Plate	Aluminum	●
	Hairline-finished Stainless Steel	■

Basic Specifications

Item	Model S800	Model S1000	Model S1400
Pallet width (mm)	800	1000	1400
Max.length (m)	100 (For Horizontal Type)		
Max. vertical rise (m)	9 (For Inclined Type)		
Inclination (degrees)	12°	0° / 12°	0°
Speed(m/min)	30		
Transportation capacity (Passengers / hour)	6750	9000	13500
Power	380V/400V/415V 50Hz		220V/380V 60Hz

Notes:

- 1)The above specifications are based on EN115.
- 2)The above specifications shall be changed according to the applied code.
- 3)Angle of inclination 0 is not applied for model S800.
- 4)Synthetic resin (yellow) demarcation line is standard for model S1400.

All Computer Graphics may differ from actual appearance.
Specifications and features are subject to change without notice.

Safety Devices

Fujitec's GS8100 series autowalk come with various safety devices designed with the priority concept of passenger's safety first.

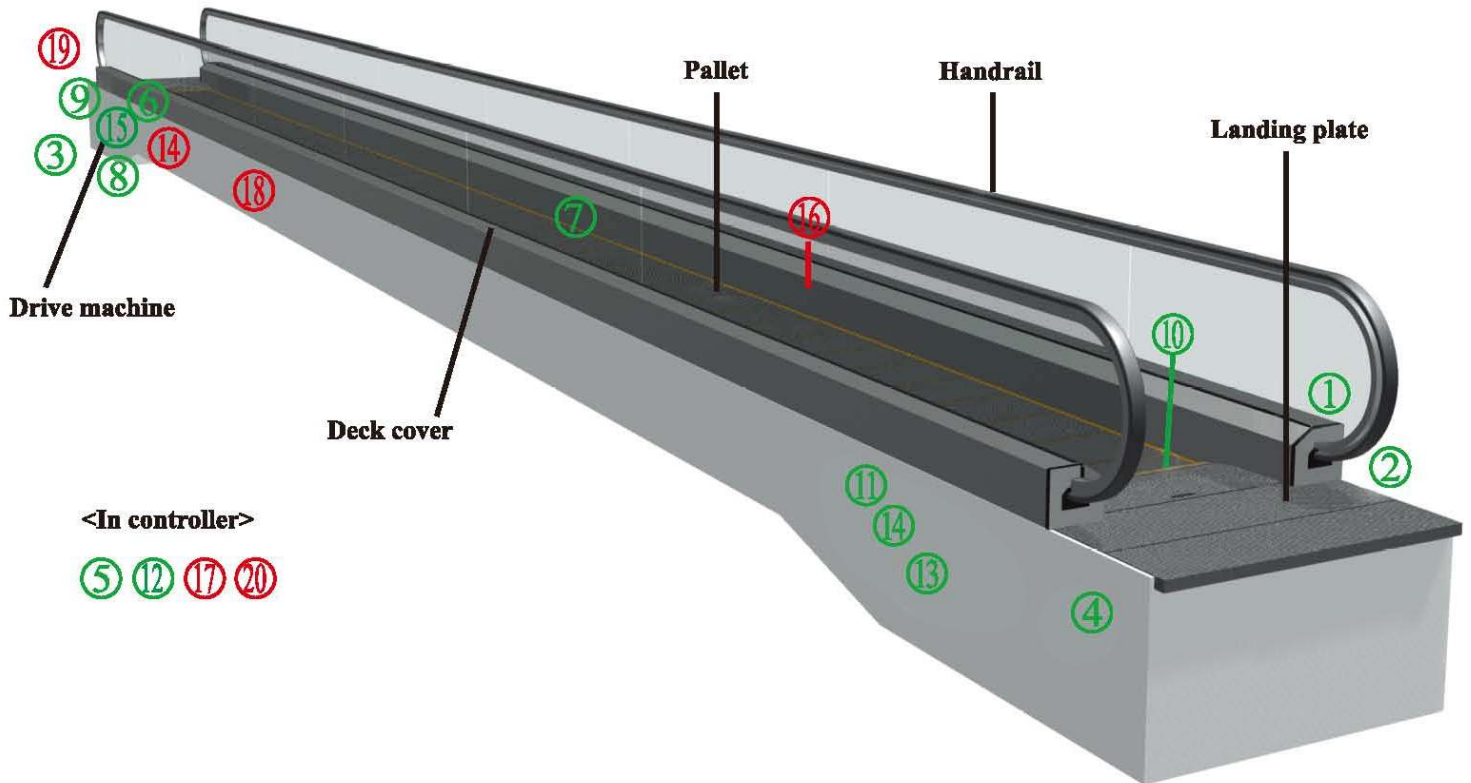

Standard safety devices

1. Handrail safety guard

Stops the autowalk when an object is caught in the handrail inlet.

2. Emergency stop button

Stops the autowalk when the button is pressed.

3. Broken drive-chain safety device

Stops the autowalk if the drive-chain is stretched or broken.

4. Broken pallet chain safety device

Stops the autowalk if the pallet chain is stretched excessively or broken.

5. Electric circuit protection device

Provided with an automatic circuit breaker to protect the autowalk circuitry and power supply parts.

6. Brake

Brake is activated to stop the autowalk by a spring force action when the power fails or any safety device is activated.

7. Demarcation line

Demarcation lines at both sides of pallet are painted yellow.

8.Reversal protection device

Stops the autowalk when reverse operation against the preset direction is commanded.(For inclined autowalk only)

9.Governor

Should the autowalk go in overspeed or in a opposite direction against the preset direction, the operation is stopped. (For inclined autowalk only)

10.Comb safety device

Stops the autowalk if a foreign object is trapped between a pallet and the comb.

11.Pallet sag safety device

Stops the autowalk before the pallets enter the comb plate when an abnormal pallet sag is detected.

12.Phase failure (phase-reversal) prevention

The autowalk operation is automatically stopped if phase failure or phase-reversal occurs.

13.Pallet missing device

Stops the autowalk if pallets are missing.

14.Handrail speed delay sensing device

Stops the autowalk if the handrail speed becomes slower than the pallet speed by more than the preset value.

15.Brake releasing sensing device

Monitor brake releasing. Autowalk can not be started if brake has not released.

Optional safety devices

16.Skirt guards

The guards are coated with a slippery fluoroplastic to enhance safety.

17.Fire shutter interlocked device

Stops the autowalk when the interlocked fire shutter, which is located near the autowalk is activated.

18.Broken handrail safety device

Stops the autowalk if either handrail is broken.

19.Auxiliary brake

A mechanically-operated auxiliary brake stops the autowalk when the governor is activated. (For an inclined autowalk only)

20.Tandem operation interlock

Should any one of the autowalks in a continuous sequence stop, all the interlocked autowalks are stopped. These autowalks are electrically interlocked to run in the same direction.

Note: Necessary safety devices shall be installed according to the applied code.

Outstanding Features

Standard Specifications

Automatic Lubrication System

A central automatic lubrication system lubricates all chains automatically. Galvanized oil collectors come with this system.

- ⇒ Smooth operation
- ⇒ Longer durability

Rubber Wheel Incorporated in Pallet Chain

Rubber Wheels integrated with pallet chain engage with sprocket.

- ⇒ Superb riding comfort
- ⇒ Exceptional smoothness & quietness

Aluminum Landing Plates

The reverse side of the floor plate can be used during the construction stage to prevent the right face of the plate from any damages by others. This plate is super-rigid because of its 40mm thickness.

- ⇒ Longer durability
- ⇒ Super rigid

Demarcation Line

Demarcation lines at the side edges of each pallet are painted by yellow color for safety. Synthetic resin yellow demarcation line is standard for pallet width 1400mm type.

- ⇒ User's safety

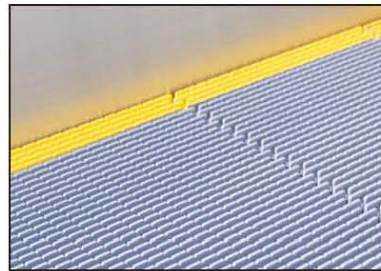

Demarcation Lines

Deluxe Balustrade

Durable stainless steel is used for the handrail frames and deck covers.

- ⇒ Longer durability
- ⇒ Luxurious appearance

Fault Display

It analyzes operational status. When a fault occurs, the cause is displayed on the screen in order to ensure efficient and proper maintenance.

- ⇒ Efficient & proper maintenance

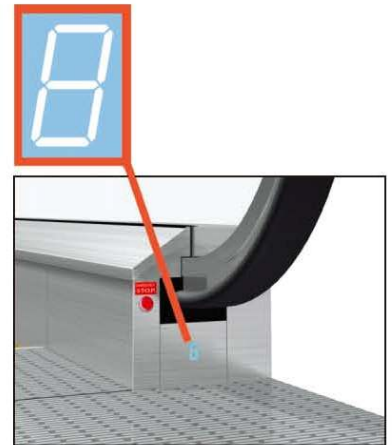

Fault Display

Color Variety Handrail

Standard Color



HRS-170 BLACK

Optional Colors



HRN-110 RED



HRN-120 ORANGE



HRN-150 GRAY



HRN-180 BEIGE

The polyurethane handrails hold the advantage of superior resistance to delamination, drive slippage, dust and vandalism.

Optional Specifications

Comb Lights

Lights are mounted on the skirt guards at the upper and lower landings, illuminating passenger's steps for easier boarding and exiting.

⇒ **User's safety**



Comb Lights

Demarcation Lights

To help passengers easily identify the boundary line between pallets, green fluorescent lights are mounted under the autowalk pallets. These are located at the upper and lower landings.

⇒ **User's safety**

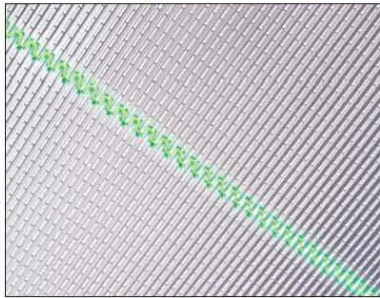

Demarcation Lights

Energy Saving System

Variable frequency operation offers the latest inverter technology, that drastically reduces power consumption. The autowalk runs at very low speed under the no load condition and resumes normal operation when approaching passengers are detected by the sensor in the poles located near the landings or the sensor by 3D Type. You can choose either 3D Sensor Type or Pole Type.

Slow speed operation prevents passengers from misunderstanding that escalators were out of service.

The length of Upper Truss is to be extended by 300mm due to the incorporation of Inverter Unit.

⇒ **User-friendly**

⇒ **Eco-conscious**

Automatic Start/Stop Operation

The sensors located near the landings detect approaching passengers and automatically start operation. The operation is stopped after all the passengers have exited. You can choose either 3D Sensor Type or Pole Type.

⇒ **User-friendly**

⇒ **Eco-conscious**

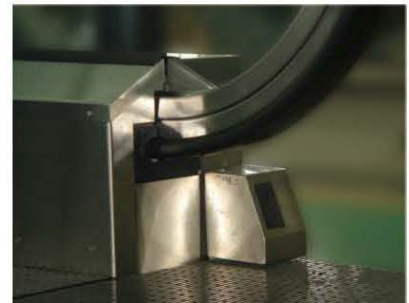

3D Sensor Type



HRN-160 CHARCOAL



HRN-140 GREEN



HRN-130 BLUE



HRN-170 BLACK

All the handrails are of polyurethane made except that HRS-170 Black is made of synthetic rubber.

*All Computer Graphics may differ from actual appearance.
Specifications and features are subject to change without notice.*

Layout Of Autowalk Inclined Type

Model S800 and S1000

(Interior Panel: Slim, Frame or Panel Type)

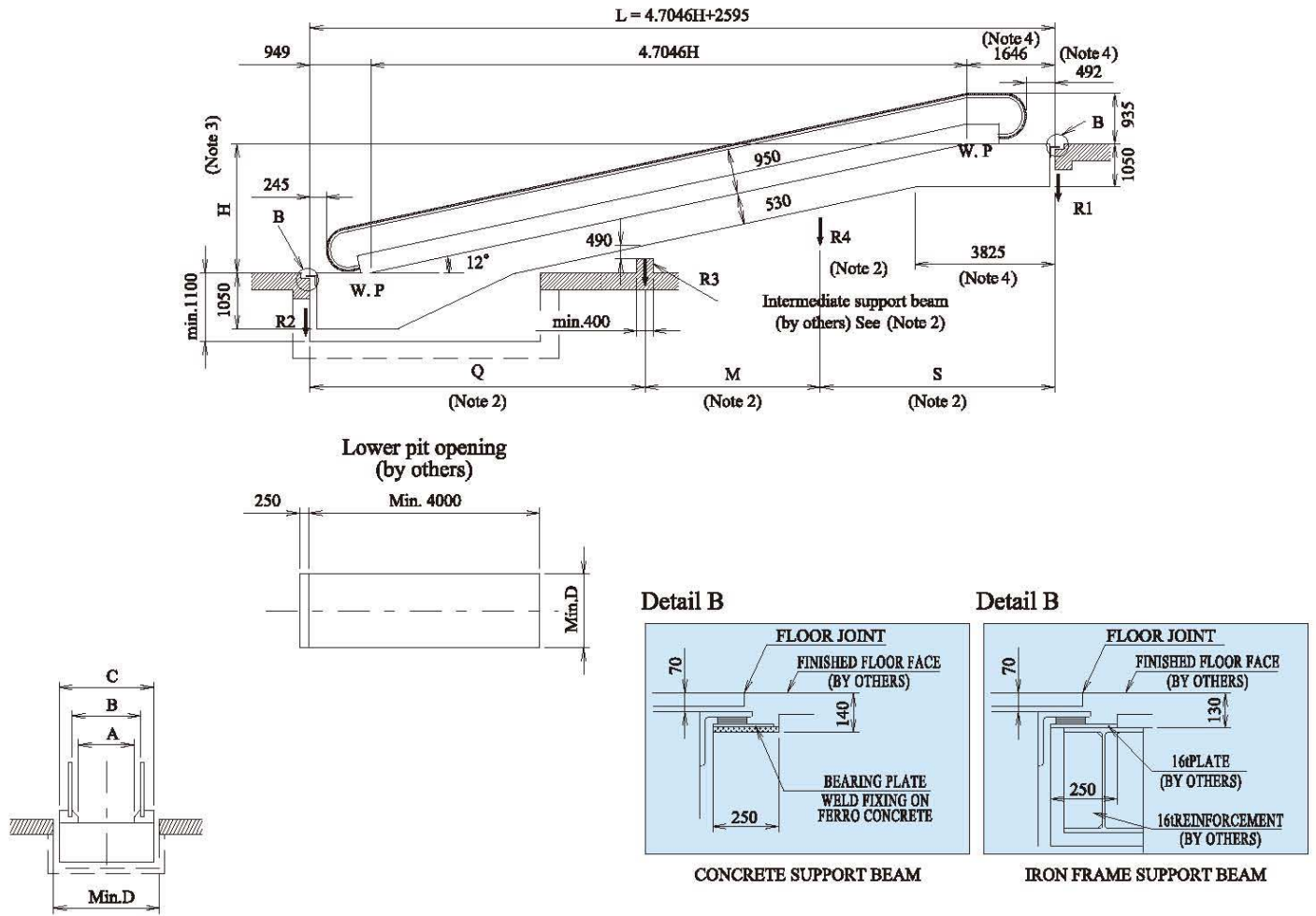

Model	S800	S1000
A	800	1000
B	1038	1238
C	1350	1550
D	1450	1650

- Notes:
- 1) If $L > 13000\text{mm}$, one intermediate support shall be required.
 - 2) $S, Q \leq 13000\text{mm}$, $M \leq 10000\text{mm}$.
 - 3) MAX.H.is 9000mm.
 - 4) Add 300mm in case of energy saving system.

Reactions (KN)

Model	Intermediate supports	R1	R2	R3	R4
S800	0	$4.04L+14.14-14.94/L$	$4.04L+4.18+14.94/L$	—	—
	1	$4.04S+14.14-20.08/S$	$4.04Q+4.18-5.14/Q$	$4.04(S+Q)+20.08/S+5.14/Q$	—
	2			$4.04(Q+M)+5.14/Q$	$4.04(S+M)+20.08/S$
S1000	0	$4.67L+14.59-15.07/L$	$4.67L+4.60+15.07/L$	—	—
	1	$4.67S+14.59-20.72/S$	$4.67Q+4.60-5.66/Q$	$4.67(S+Q)+20.72/S+5.66/Q$	—
	2			$4.67(Q+M)+5.66/Q$	$4.67(S+M)+20.72/S$

Note:
L, Q, S and M are in meters.

Layout of Autowalk Horizontal Type

Model S1000

(Interior Panel: Slim, Frame or Panel Type)

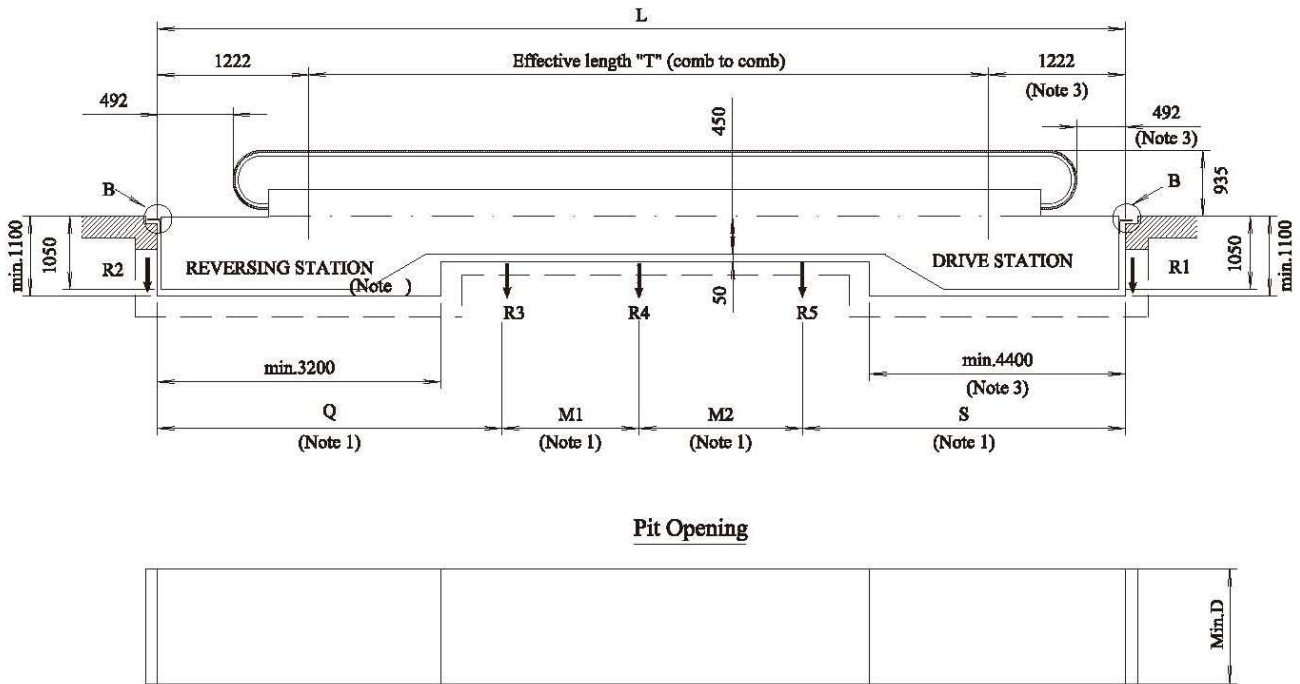

Detail B

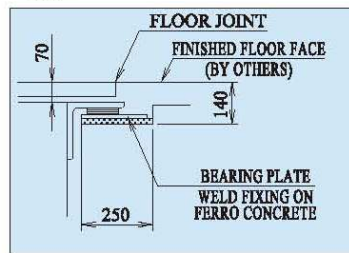

CONCRETE SUPPORT BEAM

Detail B

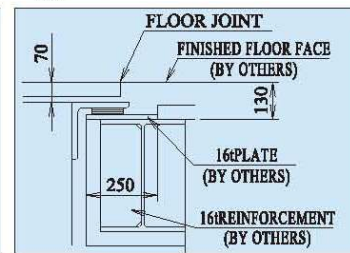

IRON FRAME SUPPORT BEAM

Model	S1000
A	1000
B	1238
C	1550
D	1650

Notes:

- 1) Max. Q, S, M1 and M2 is in 10000mm.
- 2) Max. T, is 30m for S type and 100m for F&P type
- 3) Add 300mm in case of energy saving system.

Reactions (KN)

Model	Intermediate supports	R1	R2	R3	R4	R5
S1000	1			$4.71(S+Q)+22.55/S+8.65/Q$	—	—
	2	$4.71S+14.92-22.55/S$	$4.71Q+6.56-8.65/Q$		$4.71(S+M1)+22.55/S$	—
	3			$4.71(Q+M1)+8.65/Q$	$4.71(M1+M2)$	$4.71(S+M2)+22.55/S$

Note:

Q, S, M1 and M2 are in meters.

Layout of Autowalk Horizontal Type

Model S1400

(Interior Panel: Frame or Panel Type)

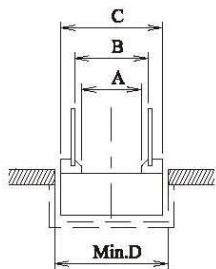
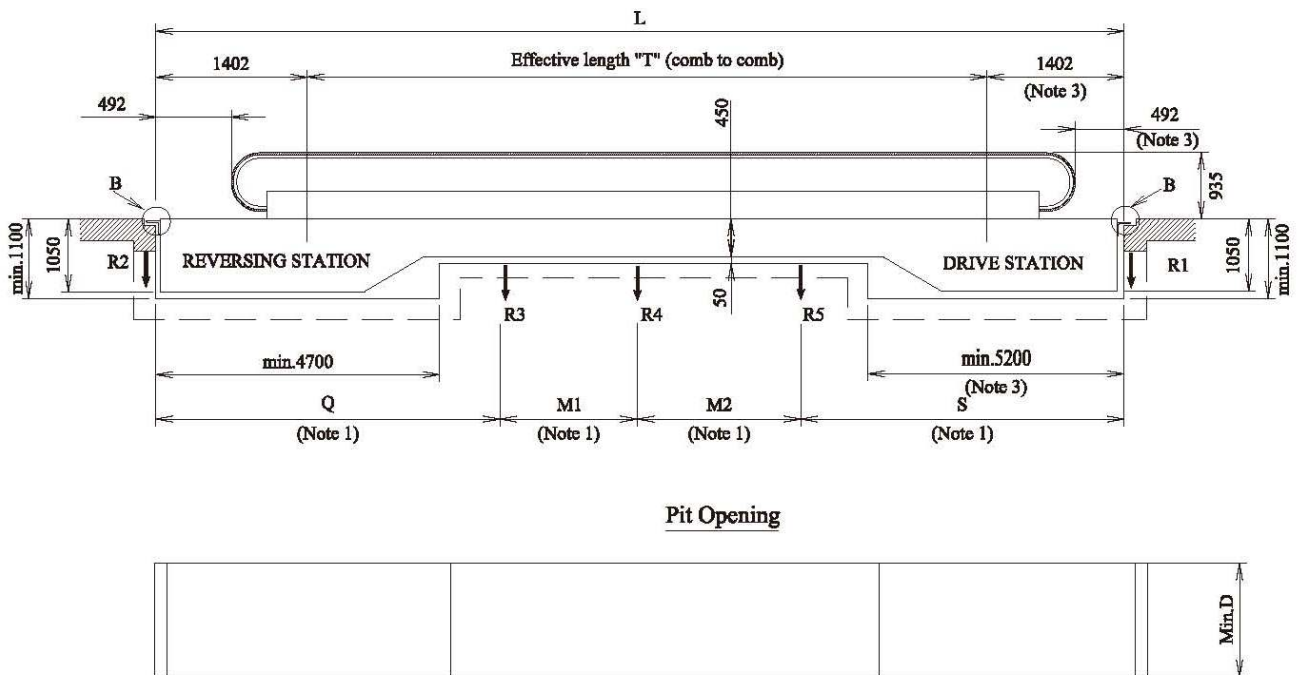

Detail B

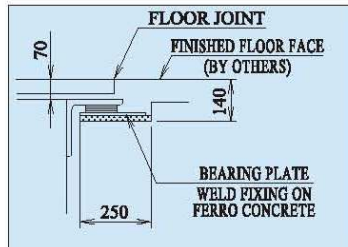

CONCRETE SUPPORT BEAM

Detail B

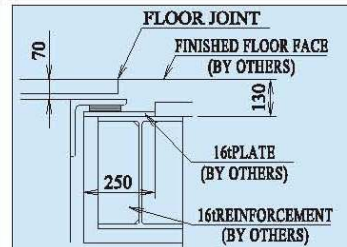

IRON FRAME SUPPORT BEAM

Model	S1400
A	1400
B	1638
C	1950
D	2050

Notes:

- 1) Max. Q, S, M1 and M2 is in 9000mm.
- 2) Max. T, is 30m for S type and 100m for F&P type

Reactions (KN)

Model	Intermediate supports	R1	R2	R3	R4	R5
S'1400	1	6.34S+18.47-29.51/S	6.34Q+7.90-14.03/Q	6.34(S+Q)+29.51/S+14.03/Q	—————	—————
	2			6.34(Q+M1)+14.03/Q	6.34(S+M1)+29.51/S	—————
	3			—————	6.34(M1+M2)	6.34(S+M2)+29.51/S

Note:

Q, S, M1 and M2 are in meters.

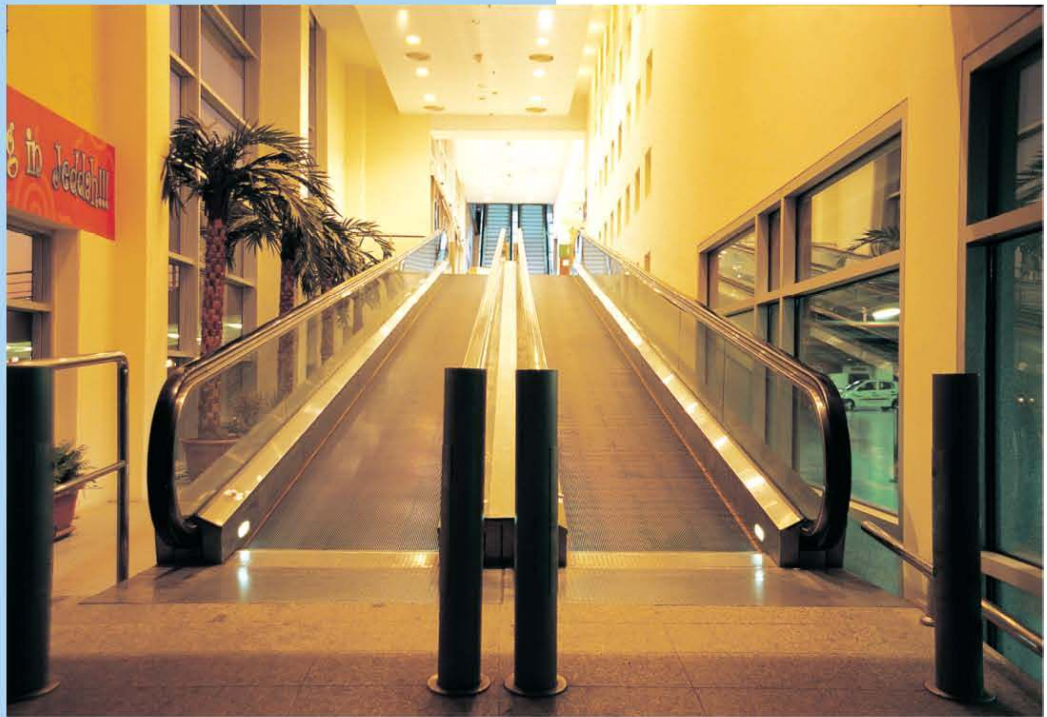

Dancoob Mall
Kingdom of Saudi Arabia

Work by Others

The following work is performed by others.

Construction work

1. Cutouts and holes for installation of autowalk.
 - Installation of support beam.
 - Installation of hook on ceiling or provision of sleeve hole in ceiling to hoist the deadweight of autowalk truss and support beam.
2. Waterproofing work for truss pit.
3. Retouching and finishing work of the areas adjacent to autowalk after installation.
4. Installation of parapets around autowalk, wedge guards and safety provisions to prevent a fall.
5. Exterior finishing work of the installed autowalk.
 - Installation of lights on exterior cladding.
6. Installation of fireproof shutters and sprinklers.
7. The work to make an entrance and to secure an access path to carry the truss into the building.
 - Restoration work after installation.
8. Work site area for materials storage.

Electrical work

1. Lead-in work of power supply (main and lighting power supply, ground wires, wiring for supervisory panel, etc.) up to control panel in the machine room.
2. Conduits and wiring from autowalk to fire shutter.
3. Provide switch for cladding light.
4. Provide electric power for the installation and adjustment work.
5. Provide emergency light.

Safety precautions to be taken around the autowalk

1. Wedge guard shall be provided under the floor ceiling at the point crossing with the autowalk (including the soffit panel of the adjacent autowalk) to prevent anyone or anything from being caught in the wedges.
2. Provide barrier plate or guard to prevent a fall, if there is an opening between autowalk and the building floor.
3. Provide safety net, if there is a clearance of 200mm or over between 2 units of autowalk or between an autowalk and a floor opening in the building.
4. Provide sign boards, notice boards or public announcement equipment so as to prohibit children from playing on or near the autowalk.

Fujitec, Ahead of Its Time

Since its foundation in 1948, Fujitec has always been contributing to modern building transport systems ahead of its time.

We are also one of the most globalized Elevator, Escalator, and Autowalk manufacturers with more than 50 sales or manufacturing locations spreading all over the world and area.

Fujitec Group Companies Hold ISO 9001 and ISO 14001

The ISO 9000 series is a set of international standards for quality assurance which have been embraced worldwide.

Fujitec Japan realized "ISO 9001" certification In March 1993. Following this achievement, Fujitec HongKong, Fujitec Singapore, Fujitec UK, Fujitec Korea, Fujitec Taiwan, Huasheng Fujitec Elevator (China) Shanghai Huasheng Fujitec Escalator (China), Fujitec Argentina, and Fujitec Egypt have received ISO9001 certification.

Furthermore, Fujitec Japan, Fujitec Singapore, Fujitec Korea, Huasheng Fujitec Elevator (china) and Shanghai Huasheng Fujitec Escalator (china) have achieved ISO14001 certification for meeting Environmental Management System Standards.

Fujitec's Global Operation

FUJITEC AMERICA, INC.
FUJITEC CANADA, INC.

NORTH AND SOUTH AMERICA

FUJITEC VENEZUELA C.A.
FUJITEC URUGUAY S.A.
FUJITEC ARGENTINA S.A.

EUROPE

FUJITEC DEUTSCHLAND GmbH
FUJITEC UK LTD.

FUJITEC EGYPT CO., LTD.
FUJITEC SAUDI ARABIA CO., LTD.
FUJITEC UAE

EAST ASIA

FUJITEC (HK) CO., LTD.
HUASHENG FUJITEC ELEVATOR CO., LTD. (CHINA)
SHANGHAI HUASHENG FUJITEC ESCALATOR CO., LTD.
FUJITEC SHANGHAI TECHNOLOGIES CO., LTD.
FUJITEC SHANGHAI SOURCING CENTER CO., LTD.
FUJITEC CHINA
FUJITEC TAIWAN CO., LTD.
FUJITEC KOREA CO., LTD.

JAPAN

FUJITEC CO., LTD.

SOUTH ASIA

FUJITEC SINGAPORE CORPN. LTD.
P.T. FUJITEC INDONESIA
FUJITEC MALAYSIA SDN. BHD.
FUJITEC INC.(PHILIPPINES)
FUJITEC INDIA PVT LTD.
FUJITEC VIETNAM CO., LTD.

FUJITEC PACIFIC, INC.(GUAM)